



V80M Marine Food Mixer - 80 Quart Mixer

Project	Item Number	Quantity
-----	-----	-----



V80M Marine is built like a ship:
To keep the water out – and to last for decades

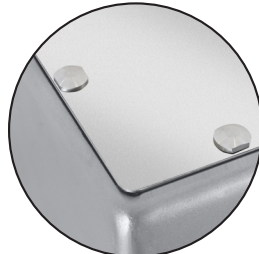

Rubber sealed cover



Secure cable



Hygiene in details



Waterproof legs



Unique ventilation cover

Standard Features

- Comply with USPHS requirements.
- IP44
- Powerful 4 hp motor for heavy duty use
- Variable Speed drive with wide agitator speed range from 50 rpm to 250 rpm
- Stainless steel construction and smooth surfaces for optimal hygiene
- Rubber sealed covers makes the mixer resistant to heavy cleaning.
- Unique ventilation cover prevents water from entering through ventilation grid
- Extra seal at cable lead-in prevents water from entering
- The machine has full welded stainless steel legs, which can be welded to the floor.
- Screws without slots ensure sanitation, and prevents bacteria collection
- Plastic bowl screen
- Front mounted controls with 90-minute timer with emergency stop
- No bowl adaptors required for the down-size bowls
- High torque transmission. Grease lubricated, anti friction ball bearings.
- Permanently lubricated planetary head
- Locking pin on tools instead of shaft.
- Safety cut-switch automatically turns the mixer off if bowl screen is opened or bowl lowered
- Overload protection and no voltage release
- 6 foot cord

Optional Features

- Watertight stainless steel planetary head

Accessories:

- 80 quart bowl - stainless steel
- Dough hook - stainless steel and double pin
- Wire whip - stainless steel
- Flat beater - Aluminum
- 42 quart bowl and accessories
- Bowl scraper in 80 and 42 quart sizes
- Stainless steel wing whip
- Stainless steel flat beater
- Reinforced whip
- Stainless steel splash guard for 80 qt bowl
- Bowl guard ingredient chute
- Bowl truck with double wheel

Warranty:

One year parts and labor limited warranty

Approved By: _____

Date _____



Varimixer

www.varimixerusa.com

14240 South Lakes Drive
Charlotte, NC 28273
Phone: 800-222-1138
Fax: 704-583-1703
mixer@varimixerusa.com



V80M Marine Food Mixer - 80 Quart Mixer

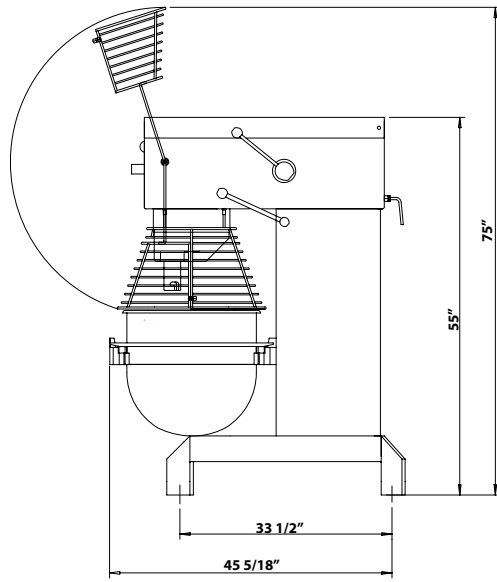

V80

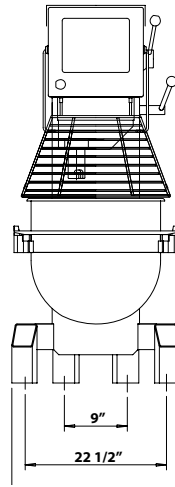

Watertight planetary head, stainless steel
Optional



Bowl truck



Bowl scraper
Optional

Specifications

Model No.	Capacity	Overall size			Net. weight
		Height H	Width W	Length L	
V80M Marine	Large bowl 80 qt.	58" (147.32 cm)	27 1/2" (69.85 cm)	44 1/2" (113.03 cm)	750 lbs.(340 kg)
	Small bowl 42 qt				

Shipping information

Class	CU. FT.	Dimensions			Weight
		Height	Width	Length	
85	65	70" (177.80 cm)	33" (83.82 cm)	49" (124.4cm)	890 lbs. (403.70 kg)

Cord & Plug	Attached 6 foot flexible 3-wire cord		
Electrical Data for Motor	Motor	Volts	Amp
Standard	4 HP	208/60/3	13
Optional	4 HP	440/60/3	6.7
Optional	4 HP	480/60/3	6.4
On the nominal motor voltage, + or - 10% tolerance is allowed.			
Mixing Speed			
Agitator Speed	Min	Max	
	50	250	

Capacity Chart

Mashed Potatoes	Whip or Beater	58 lbs.
Whipped Cream	Whip	16 Qts.
Muffins	Beater	90 lbs.
Layer Cake	Beater	92 lbs.
Pancake Batter	Whip or Beater	35 Qts
Cookie Dough	Beater or Hook	68 lbs.
Donuts, Yeast	Hook	80 lbs.
Donuts, Cake	Beater	70 lbs.
Bread Dough (65% AR)	Hook	105 lbs.
Pizza Dough (50% AR).....	Hook	90 lbs.

%AR= $\frac{\text{weight of water}}{\text{weight of flour}}$

Batch size and/or speed reduction is required if any of the following conditions exist.

1. High Gluten Flour
2. AR % under 40%
3. Water Temperature under 65 Degrees F.

 **Varimixer**
www.varimixerusa.com

14240 South Lakes Drive
Charlotte, NC 28273
Phone: 800-222-1138
Fax: 704-583-1703
mixer@varimixerusa.com