

## EasyLift Bowl Lift

Heavy bowl lifting solutions for operator labor savings and higher productivity



VLIFT-E150

### MODELS

**VLIFT-E150** EasyLift 150: 80-150 qt. Bowl Lift

### STANDARD FEATURES

- Lifts mixer bowls from 80 - 150 qts., 220 lbs.  
*\*Cannot be used with ERGO 150*
- Anodized aluminum mast with glass bead blasted stainless steel forks and handle
- Battery powered - no cords required for mobility
- 8-hour charge to 100% with 1-5 hour partial charge and green indicator light
- Overload protection and safety clutch
- Push-button lift and lowering function
- Lift height from 5.47" to 25.16"
- Bowl is lifted directly out of the mixer and driven to workstation at appropriate working height for easy handling
- Can be parked under a table when not in use for simple storage
- Made in Denmark

### STANDARD ACCESSORIES

- Charger & cable set

### WARRANTY

- Two-year parts and labor warranty

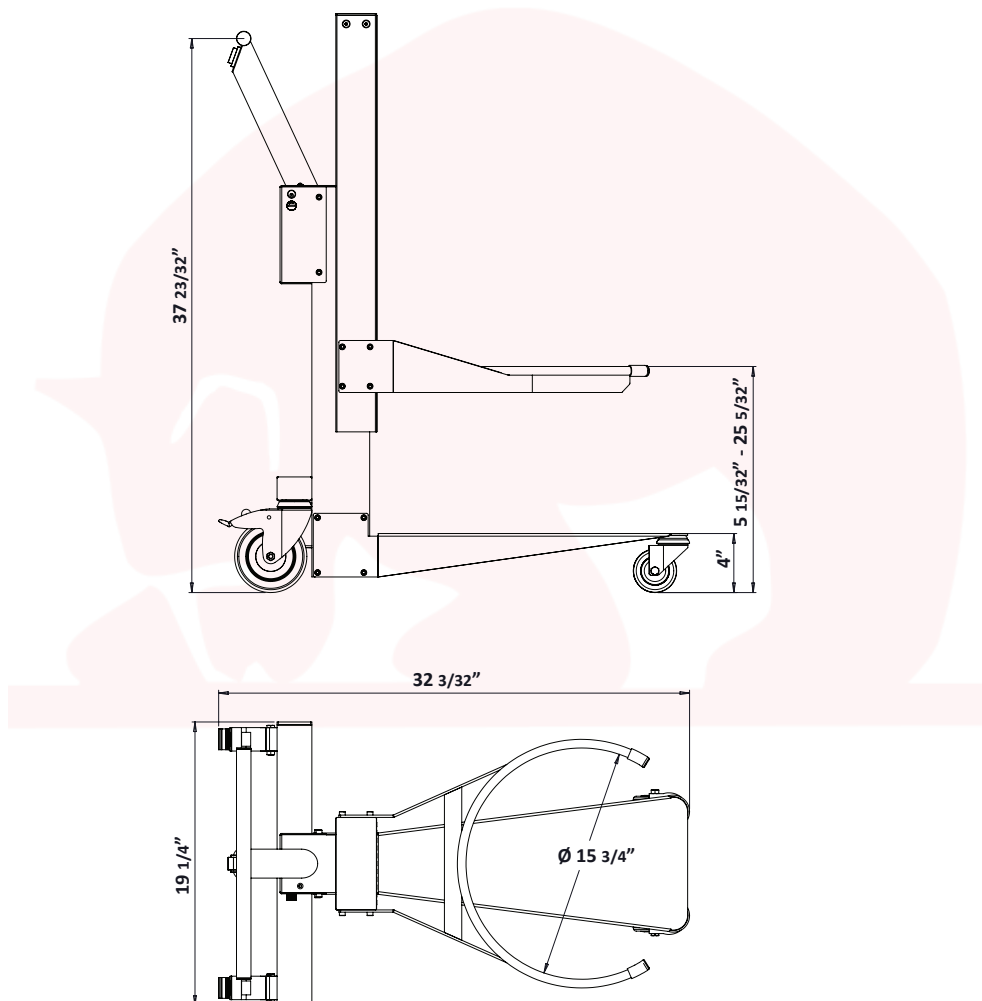

## SPECIFICATIONS

| Model      | Maximum Load | Battery    | Amp  | Charger      | Charge Time | Vibration Strength     | Sound Pressure | IP Rating |
|------------|--------------|------------|------|--------------|-------------|------------------------|----------------|-----------|
| VLIFT-E150 | 220 lbs.     | 24V, 1.2Ah | 12.4 | 230V, 2 Amps | 8 hrs.      | ≤ 2.5 m/s <sup>2</sup> | ≤ 70 Db(A)     | IP41      |

## DIMENSIONS | SHIPPING INFORMATION

**Reinforced carton for shipping. This product ships on a pallet. See dimensions below.**

| Model      | Overall Dimensions  | Net Wt.                | Shipping Dimensions                                      | Ship Wt.             | Freight Class |
|------------|---|------------------------|--|----------------------|---------------|
| VLIFT-E150 | 19.25" W x 32.1" D x 37.1" H<br>(48.9 cm x 81.5 cm x 94.2 cm) | 130 lbs.<br>(286.6 kg) | 31.5" W x 47.2" D x 21.65" H<br>(80 cm x 120 cm x 55 cm) | 94.8 lbs.<br>(43 kg) | 85            |

EasyLift 150 lifts 80 to 150 qt. bowls with maximum load of 220 lbs. Battery powered with overload protection and safety clutch. Push-button lift and lowering function. Bowl is lifted directly out of the mixer and driven to workstation at appropriate working height. Anodized aluminum mast with glass bead blasted stainless steel forks and handle. Can be parked under a table when not in use for simple storage. EasyLift cannot be used with ERGO 150. Two-year parts & labor warranty.