

V-Series 150 Qt. Marine Mixer

The kitchen workhorse, for a wide range of heavy-duty mixing applications.



MODELS

- V150PLM** 150 qt. Marine Mixer
- V150PLM-MLIFT** 150 qt. Marine Mixer with Maxilift Bowl

STANDARD FEATURES

- IP44 rated and USPHS compliant
- Stainless steel construction
- Powerful 5 HP motor for heavy-duty use with variable speed drive and agitator speed range from 47 RPMs to 257 RPMs
- Front-mounted controls with 15-minute timer, emergency stop and power bowl lift
- High torque transmission
- Grease lubricated, anti-friction ball bearings
- Removable bowl guard with patent-pending interlock
- Water cover at air ventilation
- Screws without slots to ensure sanitation
- Fully welded stainless steel knees
- Gasket at front panel, top cover and back cover
- Patent-pending interlock prevents operation if bowl guard is opened or bowl is lowered
- Overload protection and no volt release
- Non-skid rubber feet
- 6 foot cord
- ETL and NSF listed
- Made in Denmark

STANDARD ACCESSORIES

- **VBOWL-150** – Stainless steel bowl
- **VBOWL-150BRKT** – MaxiLift compatible stainless bowl (V150PL-MLIFT only)
- **VBEAT-150A** – Aluminum flat beater
- **VWHIP-150** – Stainless steel wire whip
- **VHOOK-150** – Stainless steel dough hook
- **VCHUTE** – Stainless steel ingredient chute

WARRANTY

- **NEW!** Four-year parts & labor limited warranty

OPTIONAL ACCESSORIES/ATTACHMENTS

- Bowl scraper
- Bowl truck
- Reinforced whip
- Stainless steel wing whip

To select options see back



ETL listed
Conforms to UL Std 763
Certified to CSA Std C22.2 No. 195

Approved by: _____

Date: _____

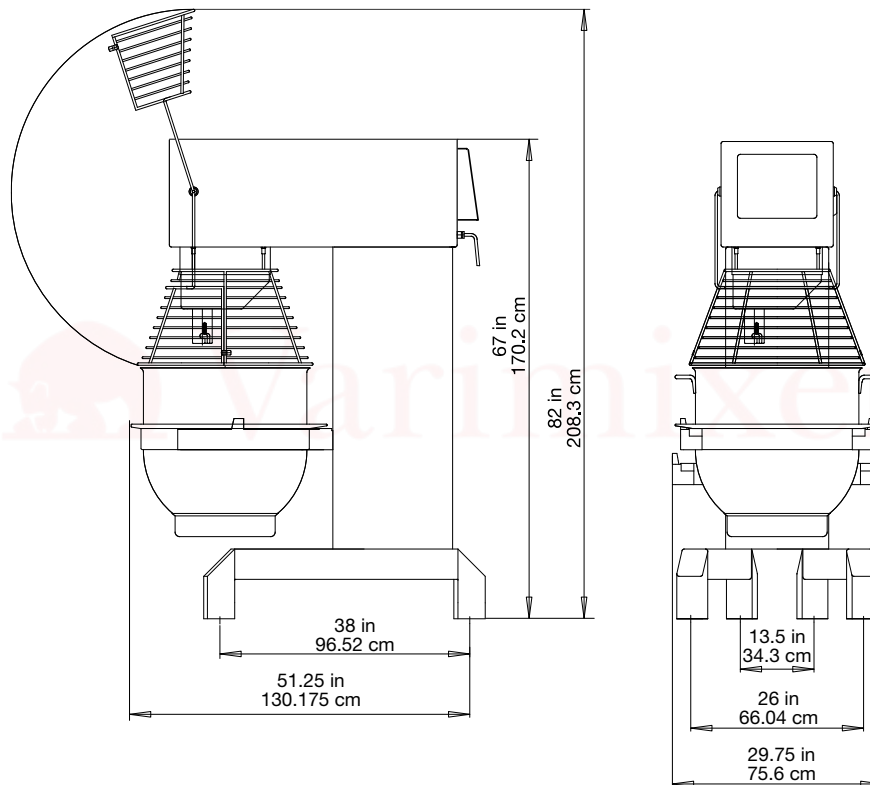

SPECIFICATIONS

Model	Motor	Volts	Amp	Plug Type	Mixing Speeds	Hub Speeds	IP Rating
V150PLM/ V150PLM-MLIFT	5 HP	208/60/3	16	--	47 - 257 RPMs	N/A	IP44

Delivered without plug. Specify voltage when ordering.

DIMENSIONS | SHIPPING INFORMATION

Reinforced carton for shipping. This product ships on a pallet. See dimensions below.

Model	Overall Dimensions	Net Wt.	Shipping Dimensions	Ship Wt.	Freight Class
V150PLM/ V150PLM-MLIFT	29.75" W x 51.25" D x 67" H (75.56 cm x 130.2 cm x 170.2 cm)	1,147 lbs. (520.27 kg)	57" W x 38.6" D x 79" H (144.8 cm x 98 cm x 200.7 cm)	1,356 lbs. (615.1 kg)	70 84 CU ft.

OPTIONAL/ADDITIONAL ACCESSORIES

- VBTRUCK-150 Bowl truck
- VBOWL-150BRKT 150 qt. Maxilift bowl
- VBEAT-150SS 150 qt. SST beater
- VWINGWHIP-150 150 qt. wire wing whip
- VHDWHIP-150 150 qt. heavy-duty wire whip
- VSCRIP-150 150 qt. scraper

Product	Tools	V150
Egg Whites	Whip	7.4 qts
Whipped Cream*	Whip	36.9 qts
Buttercream Frosting*	Whip	66.5 qts
Layer Sponge Cake	Whip	81.6 lbs
Mayonnaise	Whip	59.2 qts
Mashed Potatoes*	Beater	167.6 lbs
Cake Batter*	Beater	169.8 lbs
Fondant Icing	Beater	108 lbs
Herb Butter	Beater	185.2 lbs
Meatball Mix	Beater	152.1 lbs
Pasta Noodles (50% AR)	Hook	154.3 lbs
Dough (50% AR)	Hook	167.6 lbs
Dough (60% AR)	Hook	187.4 lbs
Dough (70% AR)	Hook	187.4 lbs
Rye Bread Dough	Hook	246.9 lbs
Sourdough Bread Dough	Hook	187.4 lbs
Gluten Free Dough	Hook	145.5 lbs

Heavy-duty 150 qt. mixer with 5 HP motor and variable speed drive with agitator speed range from 47 to 257 RPMs. Stainless steel construction with IP44 rating. Water cover at air ventilation and non-slotted screws. Front-mounted controls with power bowl lift and 15-minute timer. Watertight, permanently lubricated planetary head and attachment hub case. 6 ft. cord. Mixer is ETL and NSF certified. Four-year parts and labor limited warranty.